



s.33

1/4" - 2" EN 10226-1, heavy duty
packing gland



Quality

- 24h 100% seal test guaranteed
- Dual sealing system allows valve to be operated in either direction making installation easier
- No metal-to-metal moving parts
- No maintenance ever required
- Handle clearly shows ball position
- Silicone-free lubricant on all seals
- Chrome plated brass ball for longer life
- Handle stops on body to avoid stress at stem

Body

- Hot forged sand blasted, nickel plated brass body and cap sealed with Loctite® or equivalent threads sealant
- Finest brass according to EN 12165 and EN 12164 specifications

Stem

- Blowout-proof nickel plated brass stem
- Pure PTFE adjustable packing gland and reinforced washer for lower torque and easy maintenance

Sealing

- Pure PTFE self-lubricating seats with flexible-lip design

Threads

- EN 10226-1, ISO 228 parallel female by female threads

Flow

- 100 % full port for maximum flow

Handle

- Geomet® carbon steel handle with thick PVC dip coating. Handle coating offers both thermal and electrical protection
- **WARNING:** do not exceed reasonable temperature and/or electrical load

Working pressure & temperature

- 65 bar (940 PSI) up to 1", 40 bar (600 PSI) over 1" non- shock cold working pressure
- -40°C to +170°C (-40°F to +350°F)
- **WARNING:** freezing of the fluid in the installation may severely damage the valve

Options

- T-handle
- Oval lockable handle
- Stainless steel handle (1.4016 / AISI 430)
- Patented locking device
- Male by female threads

Upon request

- Stainless steel ball and/or stem (1.4401 / AISI 316)
- Glass filled PTFE seals
- Custom design

PED directive

- According to 2014/68/UE module A: it cannot be used with dangerous gases in sizes larger than 25mm

Approved by or in compliance with

- GOST-R (Russia)
- EAC - Declaration of conformity (Russia, Kazakhstan, Belarus)
- RoHS Compliant (EU)

NOTE: approvals apply to specific configurations/sizes only.



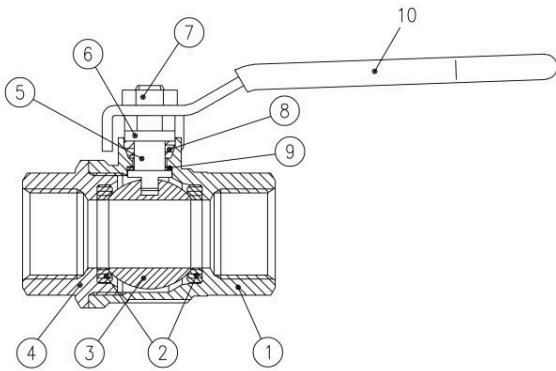

	PART DESCRIPTION	Q.TY	MATERIAL
1	Nickel plated body	1	CW617N
2	Seat	2	PTFE
3	Chrome plated ball	1	CW617N
4	Nickel plated end-cap	1	CW617N
5	Nickel plated stem packing gland design	1	CW617N
6	Nickel plated gland nut	1	CW617N
7	Geomet® nut	1	CB4FF (EN10263-2)
8	Packing gland seal	1	PTFE
9	Washer	1	PTFE carbon filled 25%
10	Black PVC coated Geomet® steel handle	1	DD11 (EN10111)

1.1/4"- 2" hollow ball

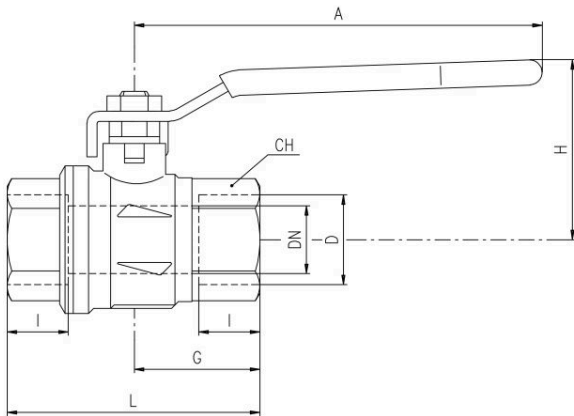

Code	S33B00	S33C00	S33D00	S33E00	S33F00	S33G00	S33H00	S33I00
D (inch)	1/4	3/8	1/2	3/4	1	1 1/4	1 1/2	2
DN (mm)	8	10	15	20	25	32	40	50
I (mm)	12.5	12.5	15.5	18	21	23	24.5	26.5
L (mm)	51	51	61	74.5	90.5	104	117	135
G (mm)	25.5	25.5	30.5	37	45.5	52	59	67.5
A (mm)	82	82	100	120	120	158	158	158
H (mm)	39.5	39.5	43	52.5	57	78	85	92
CH (mm)	22	22	27	32	41	50	55	70
PN (Bar)	65	65	65	65	65	40	40	40
Kv (m ³ /h)	4.1	8.7	28	60	100	95	179	233

Ball valves are marked CE on handle from 1.1/4" to 2" as follow:
CE XXCODEXX Cat I-A

Pressure-temperature chart

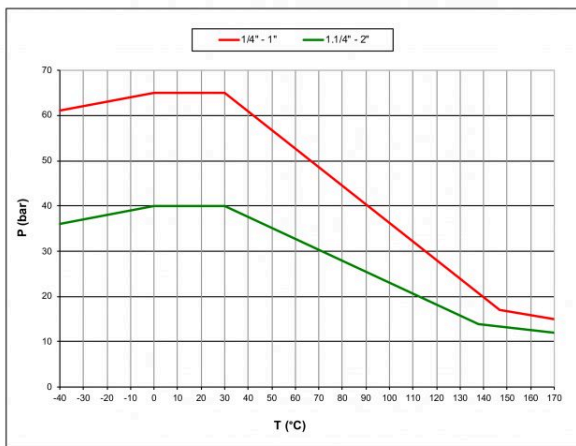

Pressure drop chart

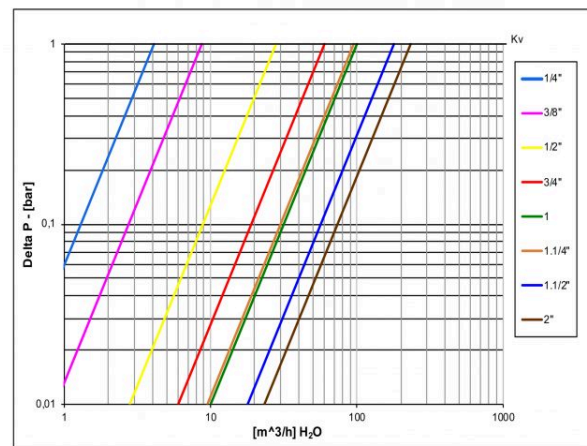

Ask for additional information on the whole range of **RUB** products and consult with your supplier for special applications.
For complete disclaimer: www.rubvalves.com/disclaimer