

WAFER Disc Check Valve

- WAFER swing or tilting disc check valve (can be manufactured with flanges on request).
- One-piece cast body which provides easy evacuation of solid particles contained in the fluid.
- Face-to-face dimension in accordance with CMO standard.
- It has an arrow on the body indicating the flow direction.
- Can be supplied with auxiliary spring to obtain faster sealing.
- For high water loads or large valve diameters hydraulic damping systems can be incorporated which reduce the valve's impact in the sealing.
- The **R** check valve allows the fluid to flow through in one direction, it is opened by the fluid passing through and it closes due to the weight of the disc and the return of the fluid.

General Applications:

- This valve is suitable for liquids that contain a maximum of 5% suspended solids.
- Designed for a wide range of applications such as:
 - Paper Industry.
 - Chemical plants.
 - Sewage treatment.
 - Pumping.
 - Etc.

Sizes:

- From ND50 to ND1.200.
- Larger sizes on request.

Working Pressure:

- From ND50 to ND600: Maximum PN 64.
- From ND700 to ND1.200: Maximum PN 25.

Flange connection:

- The standard flange connection is according to DIN PN10. Other flange connections are available on request, such as:
 - ANSI 150.
 - Australian Standard.
 - DIN PN6.
 - DIN PN16.
 - DIN PN25.
 - British Standard.
 - JIS Standard.

Directives:

- Machinery Directive: **DIR 2006/42/EC (MACHINERY)**.
- Pressure Equipment Directive: **DIR 97/23/EC (PED) ART.3, P.3.**
- Potential Explosive Atmospheres Directive: **DIR 94/9/CE (ATEX) CAT.3 ZONE 2 and 22 GD.** For further information on categories and zones please contact the CMO Technical-Commercial Dept.

Quality Dossier:

- All valves are tested hydrostatically at CMO and material and test certificates can be provided.
- Body test = Maximum working pressure x 1.5.
- Seal test = Maximum working pressure x 1.1 (Excellent watertight integrity according to API 598).

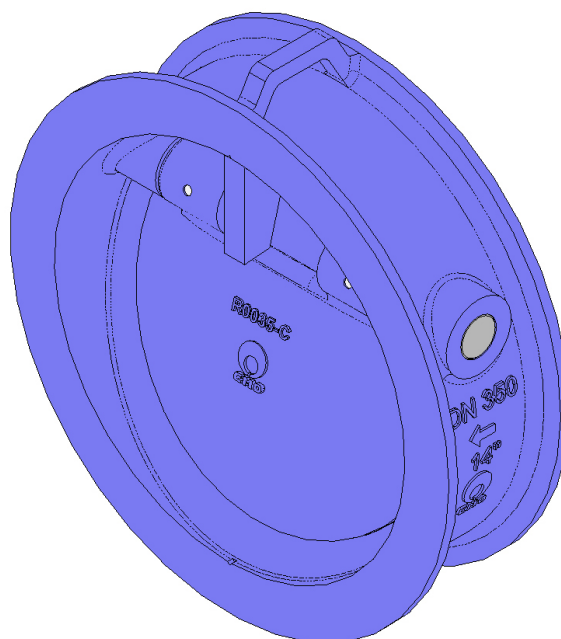

fig. 1

CHECK VALVES

R SERIES

Advantages of CMO's "Model R" compared to similar products

- Reduced space.
- No maintenance needed.
- Minimum pressure drops.
- Easy assembly.
- No spare parts needed.
- Minimum leakage with metal/metal seat.



fig. 2

POS.	DESCRIPTION	MATERIAL 1	MATERIAL 2
1	BODY	CF8M	A216WCB+AISI304
2	DISC	CF8M	A216WCB+AISI304
3	STEM	AISI316	AISI304
4	CAP	AISI316	F-111

table 1

1- BODY

Wafer-type construction. One-piece cast body which provides easy evacuation of solid particles contained in the flow.

For diameters greater than ND1200 the body is machine-welded with reinforcements to resist the working pressure.

The body's internal design provides small pressure drops and prevents any build up of solids in the seat area.

The standard manufacturing materials are CF8M stainless steel and A216WCB carbon steel (starting from ND250). When the A216WCB carbon steel body is required AISI 304 stainless steel is added to the seat area to ensure a stainless steel metal/metal seat.

Other materials such as: GJS-500 nodular cast iron and stainless steel alloys (AISI316Ti, Duplex, 254SMO, Uranus B6...) are available on request. As standard, iron or carbon steel valves are painted with an anti-corrosive protection of 80 microns of EPOXY (colour RAL 5015). Other types of anti-corrosive protections are available on request.

2- DISC

The standard manufacturing materials are CF8M stainless steel and A216WCB carbon steel. When the A216WCB carbon steel body is required AISI 304 stainless steel is added to the seat area to ensure a stainless steel metal/metal seat.

For diameters greater than ND1200 the body is machine-welded with reinforcements to resist the working pressure.

C.M.O.

Amategui Aldea 142, 20400 Txarama-Tolosa (SPAIN)

TEC-R.EN03

Tel. Nacional: 902.40.80.50 Fax: 902.40.80.51 / Tel. Internacional: 34.943.67.33.99 Fax: 34.943.67.24.40

cmo@cmo.es <http://www.cmo.es>

page 2

CHECK VALVES

R SERIES

Other material such as GJS-500 nodular cast iron and stainless steel alloys (AISI316Ti, Duplex, 254SMO, Uranus B6...) are available on request.

As standard, iron or carbon steel valves are painted with an anti-corrosive protection of 80 microns of EPOXY (colour RAL 5015). Other types of anti-corrosive protections are available on request.

3- SEAT (fig. 3)

This valve is made watertight via contact between the body and the disc. They are both precision machined to ensure the best possible contact.

When the valve is manufactured in CF8M stainless steel, the seat is CF8M on the body and CF8M on the disc.

When the valve is manufactured in A216WCB carbon steel, AISI 304 stainless steel is added to the seat surface, on the body and the disc.

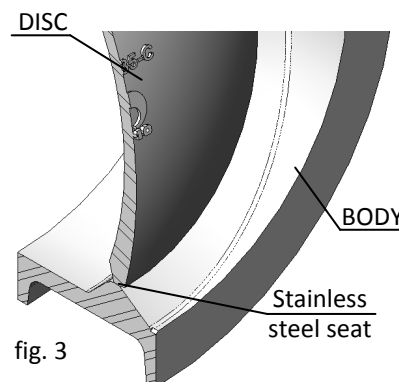

4- STEM

In check valves manufactured in CF8M stainless steel the stem is supplied in AISI316.

In check valves manufactured in A216WCB carbon steel the stem is supplied in AISI304.

The stem is supplied in two parts and the valve construction is sealed with a welded cap on the ends.

ACCESSORIES AND OPTIONS

CMO check valves can be supplied with the following accessories:

Spring Loaded Disc (fig. 4):

The valves can be supplied with a stainless steel spring on the stem, which will assist during the closing operation and will increase the closing speed.

Counterweight and/or Shock absorber (fig. 5):

The counterweight and shock absorber system is used to control the disc closing speed and, at the same time, to reduce the effects of the water hammer. The shock absorber is composed of a hydraulic cylinder and an oil tank which are connected via hydraulic piping.

DETAIL OF SHAFT WITH SPRING

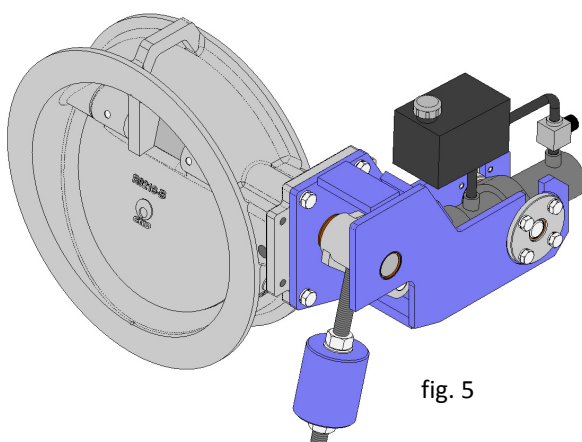
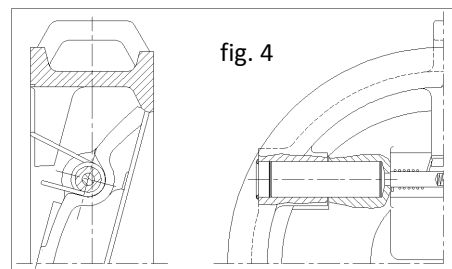

A flow regulating valve is located in the hydraulic piping, to enable the regulation of the oil that moves from one chamber to the other in the cylinder.

This flow regulating valve must be installed in such a way that when the valve is opening (cylinder rod extending) it allows the oil to flow through freely whilst when the valve is closing (cylinder rod contracting) the oil flow is cut.

The counterweight is used to counteract the friction created by the shock absorber. The arm of the counterweight is a threaded bar on which the position of the weight can be moved and locked via nuts.

Note: It is very important to inform our technical department whether the valves should be installed horizontal or vertical piping.

C.M.O.

Amategui Aldea 142, 20400 Txarama-Tolosa (SPAIN)

TEC-R.EN03

Tel. Nacional: 902.40.80.50 Fax: 902.40.80.51 / Tel. Internacional: 34.943.67.33.99 Fax: 34.943.67.24.40

cmo@cmo.es <http://www.cmo.es>

page 3

CHECK VALVES

R SERIES

GENERAL DIMENSIONS

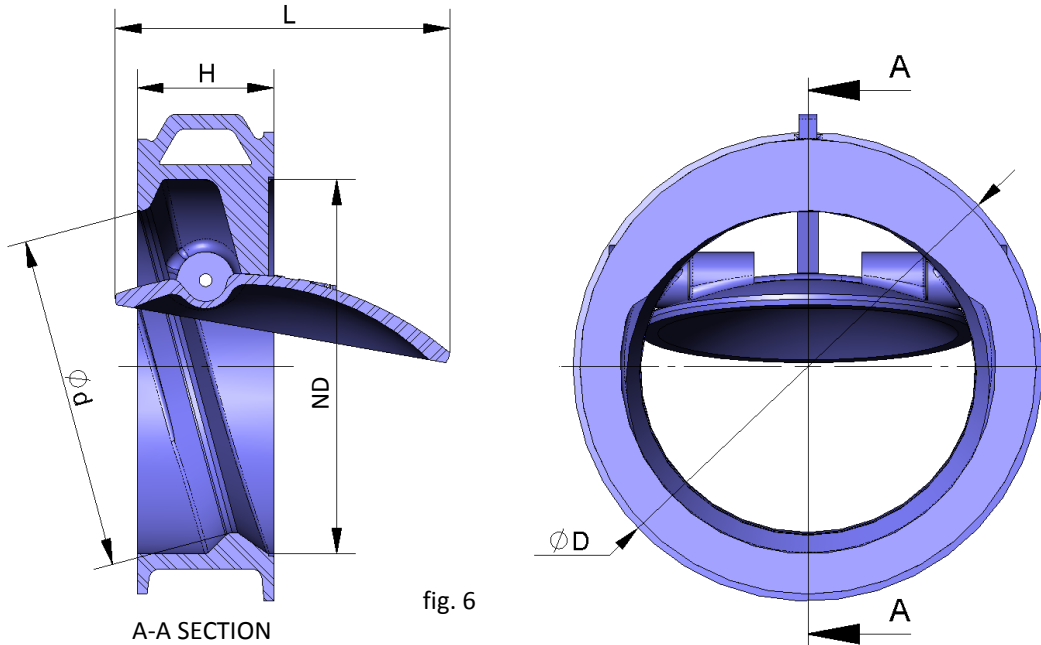

fig. 6

- Bodies larger than ND1.200, machine-welded construction.
- Option to integrate spring or counterweight.
- For more ND-s consult CMO.

ND	D								d	H	L	Weight
	PN6	PN10	PN16	PN25	PN40	PN64	ASA150	ASA300				
40	87	94	94	94	94	103	83	93	34	33	45	0,6
50	97	107	107	107	107	113	102	109	44	43	60	1
65	117	127	127	127	127	138	121	128	58	46	70	1,1
80	132	142	142	142	142	148	134	147	72	64	90	2
100	152	162	162	162	168	174	172	178	90	64	102	3
125	182	194	194	194	194	211	194	213	112	70	120	4
150	207	219	219	224	224	248	219	248	135	76	140	6
200	262	273	273	284	291	310	273	305	180	89	185	10
250	317	329	329	340	352	365	337	359	225	114	220	15
300	373	378	384	401	418	425	407	420	270	114	262	21
350	423	438	444	458	475	487	448	483	315	127	310	30
400	473	490	496	515	547	544	512	537	365	140	360	40
450	528	539	556	565	586	603	547	594	420	152	400	52
500	578	594	618	625	629	657	604	652	460	152	450	62
600	679	696	735	732	747	764	715	771	555	178	535	94
700	784	811	805	834	852	879	828	895	650	229	620	172
800	891	918	912	943	974	988	935	1.004	740	241	715	236
900	991	1.018	1.012	1.043	1.084	1.108	1.043	1.115	835	275	800	303
1.000	1.091	1.124	1.128	1.154	1.194	1.220	--	--	940	300	920	564
1.200	1.307	1.341	1.342	1.364	1.398	1.452	--	--	1.140	350	1.147	--

table 2

C.M.O.

Amategui Aldea 142, 20400 Txarama-Tolosa (SPAIN)

TEC-R.EN03

Tel. Nacional: 902.40.80.50 Fax: 902.40.80.51 / Tel. Internacional: 34.943.67.33.99 Fax: 34.943.67.24.40

cmo@cmo.es <http://www.cmo.es>

page 4

CHECK VALVES

R SERIES

WITH SHOCK ABSORBER AND COUNTERWEIGHT

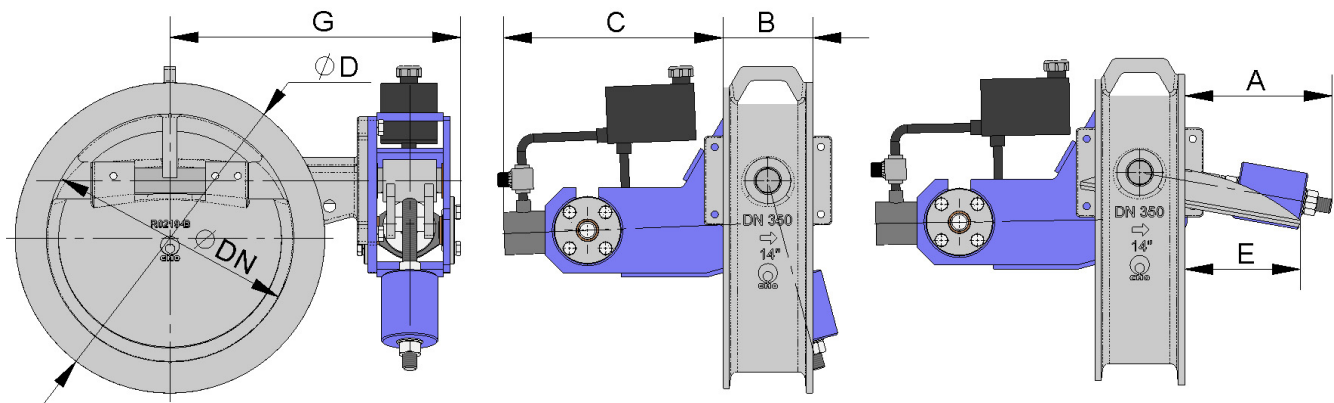

fig. 7

- In valve diameters equal to or lower than ND100, there is the possibility of placing **only with counterweight**, without the option of shock absorber.
- For more ND-s consult CMO.

ND	D								A	B	C	E	G
	PN6	PN10	PN16	PN25	PN40	PN64	ASA150	ASA300					
50	97	107	107	107	107	113	102	109	121	43	--	17	225
65	117	127	127	127	127	138	121	128	121	46	--	24	240
80	132	142	142	142	142	148	134	147	121	64	--	26	255
100	152	162	162	162	168	174	172	178	138	64	--	35	272
125	182	194	194	194	194	211	194	213	138	70	240	50	280
150	207	219	219	224	224	248	219	248	142	76	245	67	285
200	262	273	273	284	291	310	273	305	155	89	250	96	309
250	317	329	329	340	352	365	337	359	160	114	261	110	330
300	373	378	384	401	418	425	407	420	160	114	270	145	356
350	423	438	444	458	475	487	448	483	215	127	308	168	398
400	473	490	496	515	547	544	512	537	230	140	334	190	452
450	528	539	556	565	586	603	547	594	382	152	367	221	515
500	578	594	618	625	629	657	604	652	428	152	398	252	580
600	679	696	735	732	747	764	715	771	472	178	412	319	609
700	784	811	805	834	852	879	828	895	510	229	443	380	659
800	891	918	912	943	974	988	935	1.004	590	241	346	390	730
900	991	1.018	1.012	1.043	1.084	1.108	1.043	1.115	590	275	365	468	805
1.000	1.091	1.124	1.128	1.154	1.194	1.220	--	--	623	300	370	526	825
1.200	1.307	1.341	1.342	1.364	1.398	1.452	--	--	645	350	392	587	1.044

table 3

C.M.O.

Amategui Aldea 142, 20400 Txarama-Tolosa (SPAIN)

TEC-R.EN03

Tel. Nacional: 902.40.80.50 Fax: 902.40.80.51 / Tel. Internacional: 34.943.67.33.99 Fax: 34.943.67.24.40

cmo@cmo.es <http://www.cmo.es>

page 5



CHECK VALVES

R SERIES

COMPONENTS LIST (Standard version)



fig. 8

PART No.	NAME
1	BODY
2	DISC
3	STEM
4	CAP

table 4

CHECK VALVES

R SERIES

COMPONENTS LIST (Counterweight + shock absorber version)

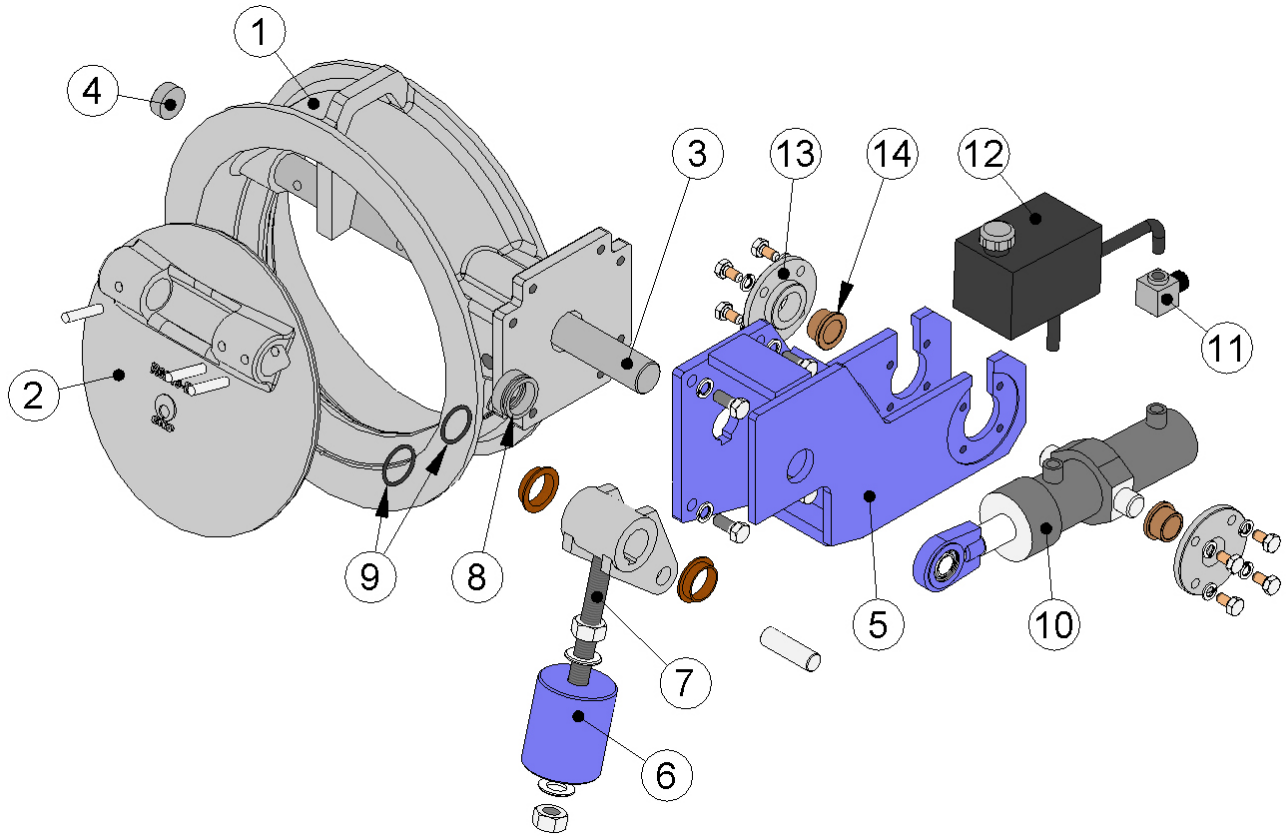

fig. 9

PART No.	NAME
1	BODY
2	DISC
3	STEM
4	CAP
5	SUPPORT
6	COUNTERWEIGHT
7	LEVER
8	SOCKET
9	JOINT
10	CYLINDER
11	REGULATOR
12	TANK
13	CYLINDER COVER
14	CYLINDER SOCKET

table 5

C.M.O.

Amategui Aldea 142, 20400 Txarama-Tolosa (SPAIN)

TEC-R.EN03

Tel. Nacional: 902.40.80.50 Fax: 902.40.80.51 / Tel. Internacional: 34.943.67.33.99 Fax: 34.943.67.24.40

cmo@cmo.es <http://www.cmo.es>

page 7