

STOP VALVE	467064
	467063
	PN 40
	PN 25

No	Part	Material
1	Body	Cast steel GSC25
2	Bonnet	Cast steel GSC25
3	Seat ring	Stainless steel 1.4301
4	Disc	Stainless steel X20Cr13
5	Stem	Stainless steel X20Cr13
6	Handwheel	Cast iron
7	Glandpacking	Graphite
8	Gland	Cast steel GSC25
9	Gasket	Graphite
10	Bolt/Nut	Steel, zincplated

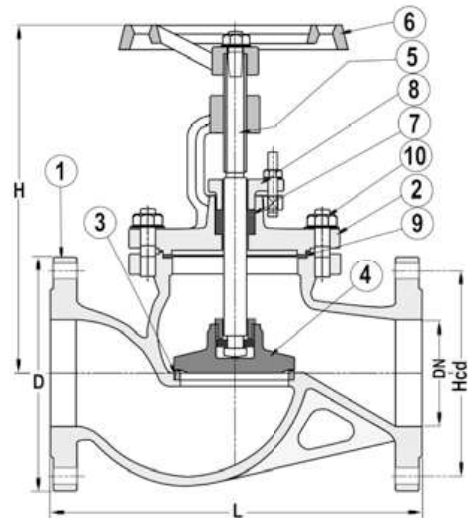

**Variants:**  
 S.D.N.R. = Non-return disc  
 R = Parabolic disc  
 Rg5 = Bronze trim  
 Various actuators  
 DN200-300 available PN40  
 Other dimensions/materials on request

DN	D	n x Ød	Hcd	L	Hmax	Max working-pressure		Weight Kg
						Mpa 120 °C	Mpa 400 °C	
15	95	4x14	65	130	189	4,0	2,1	5,2
20	105	4x14	75	150	189	4,0	2,1	5,8
25	115	4x14	85	160	203	4,0	2,1	7,6
32	140	4x18	100	180	216	4,0	2,1	9,0
40	150	4x18	110	200	246	4,0	2,1	13,1
50	165	4x18	125	230	259	4,0	2,1	15,1
65	185	4x18	145	290	313	4,0	2,1	26,0
80	200	8x18	160	310	317	4,0	2,1	33,0
100	235	8x22	190	350	381	4,0	2,1	44,0
125	270	8x26	220	400	452	4,0	2,1	71,0
150	300	8x26	250	480	476	4,0	2,1	100,0
<b>467063 PN25</b>								
200	360	12x26	310	600	643	2,5	1,3	170,0
250	425	12x30	370	730	780	2,5	1,3	283,0
300	485	12x30	430	850	890	2,5	1,3	414,0