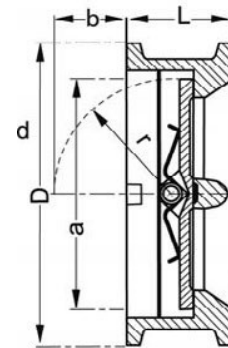
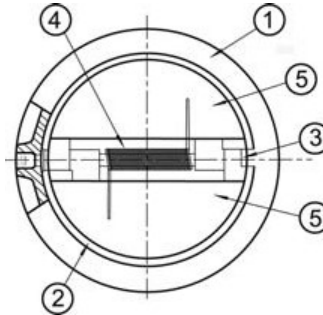

## DUAL CHECK VALVE

**315102**
**315101**
**PN 16**
**PN 10**

No	Part	Material
1	Body	Nodular cast iron GGG40.3
		Epoxy coated
2	Seal	NBR
3	Shaft	Stainless Steel
4	Spring	Stainless Steel
5	Plate	Alu.-Bronze

**Variants:**

Rubber-lined

DN 350-600 available PN16

Other dimensions/materials on request

 Wafer-type to be mounted  
between flanges

DN	D	a	b	r	L	Max working-pressure		Weight Kg
						Mpa 200 °C	Mpa °C	
40	94	58	18	33	43	1,6		1,0
50	109	58	12	33	43	1,6		1,5
65	129	58	12	33	46	1,6		2,5
80	144	70	18	41	64	1,6		3,8
100	164	95	28	52	64	1,6		5,0
125	194	128	35	70	70	1,6		6,8
150	220	132	33	70	76	1,6		8,0
200	275	192	60	104	89	1,6		15,0
250	330	244	81	126	114	1,6		27,0
300	380	295	100	153	114	1,6		34,0
<b>315101 PN10</b>								
350	440	320	108	168	127	1,0		53,0
400	491	380	137	195	140	1,0		70,0
450	539	420	152	217	152	1,0		100,0
500	596	480	175	247	152	1,0		130,0
600	698	538			178	1,0		130,0