

UNIVERSAL FLANGE ADAPTOR

TECHNICAL PASSPORT

UNIVERSAL FLANGE ADAPTOR

ADTUNIA

APPLICATION

The universal flange adaptors are used as a junction products between flanges and pipes or tube of various material: steel, cast iron, PVC, etc.



Fluids : drinking water, clear water , compatible loaded liquids.

GENERAL CHARACTERISTICS

Range : from DN40 to DN1000.
 Connection PN10/PN16 with multiple flange holes.
 Stainless steel bolts and nuts.
 Lockable flange from DN80 to DN600.
 With plastic cap protection.



ACS

Epoxy coated body according to EN 14901
 RAL 5015, 250 µm thickness

CONSTRUCTION DN40-65

Pos.	Description	Material	Standard
1	Body	Ductile iron GGG50	EN 1563
2	Counter flange	Ductile iron GGG50	EN 1563
3	Screw*	Stainless steel AISI 304	1449-2 304 S15
4	Gasket	EPDM ACS	EN 681-1

* In option Stainless steel AISI 316

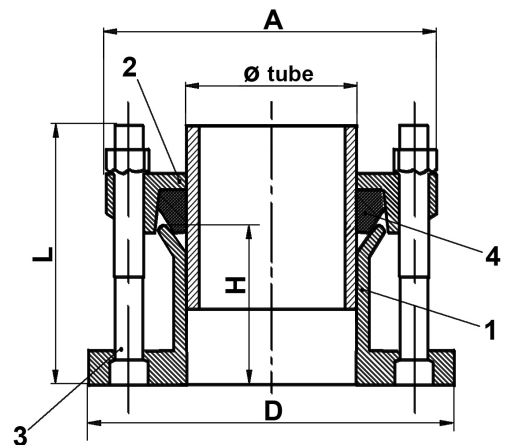

DIMENSIONS

DN		Ø tube	A	H	L	D	Weight (kg)
mm	inch						
DN40	1"1/2	48-60	150	80	M12X130	150	3.2
DN50	2"	59-70	156	80	M12X130	165	3.9
DN65	2"1/2	72-85	174	80	M12X130	190	4.1

PRODUCT APPROVALS

ERAC **ACS** Health compliance certificate n° 21 ACC LY 832

Tecofi France

83 rue Marcel Mérieux - 69960 Corbas
 Tél. +33 (0)4 72 79 05 79 - Fax. +33 (0)4 78 90 19 19
 E-mail : sales@tecofi.fr - www.tecofi.fr



UNIVERSAL FLANGE ADAPTOR

TECHNICAL PASSPORT

UNIVERSAL FLANGE ADAPTOR

ADTUNIA

CONSTRUCTION DN80-600

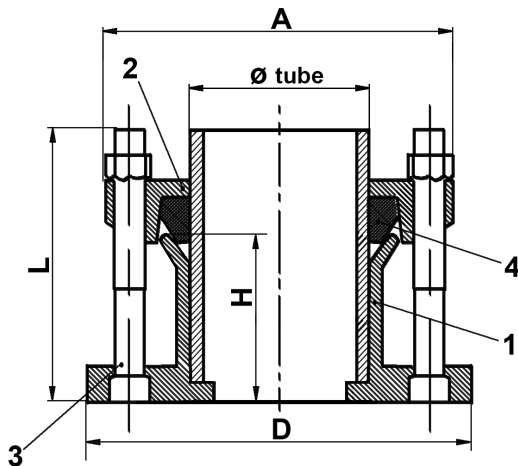

DN80-100 and DN150-350

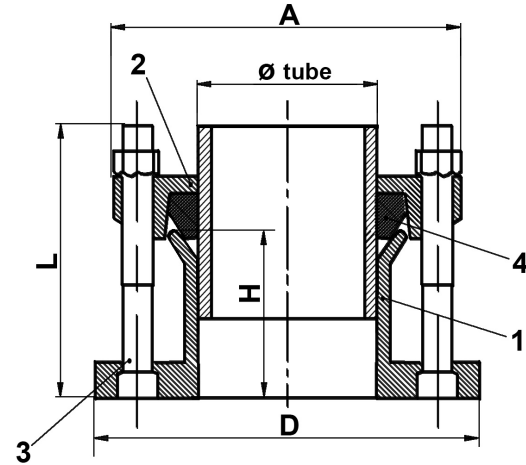

DN125 and DN400-600

Pos.	Description	Material	Standard
1	Body	Ductile iron GGG50	EN 1563
2	Counter flange	Ductile iron GGG50	EN 1563
3	Screw*	Stainless steel AISI 304	1449-2 304 S15
4	Gasket	EPDM ACS	EN 681-1

* In option Stainless steel AISI 316

DIMENSIONS

Epoxy coated body according to EN 14901
RAL 5015, 250 µm tickness

DN		Ø tube	A	H	L	D	Weight (kg)
mm	inch						
DN80	3"	88-98	105	82	M12X130	205	4.2
DN100	4"	114-118	124	82	M12X130	216	5.3
DN125	5"	139-144	148	82	M12X140	255	5.6
DN150	6"	168-170	176	82	M12X140	285	8.7
DN200	8"	219-222	227	82	M12X140	346	9
DN250	10"	273-274	278	92	M12X150	414	11.3
DN300	12"	323-326	335	93	M12X150	455	19.9
DN350	14"	340-360	362	117	M14X170	485	22.4
DN400	16"	390-410	413	100	M14X150	580	28.5
DN450	18"	436-462	462	115	M14X180	640	35
DN500	20"	500-508	510	115	M14X180	715	70
DN600	24"	608-636	638	135	M14X200	835	98.5

Tecofi France

83 rue Marcel Mérioux - 69960 Corbas
Tél. +33 (0)4 72 79 05 79 - Fax. +33 (0)4 78 90 19 19
E-mail : sales@tecofi.fr - www.tecofi.fr



UNIVERSAL FLANGE ADAPTOR

TECHNICAL PASSPORT

UNIVERSAL FLANGE ADAPTOR

ADTUNIA

CONSTRUCTION DN700-1000

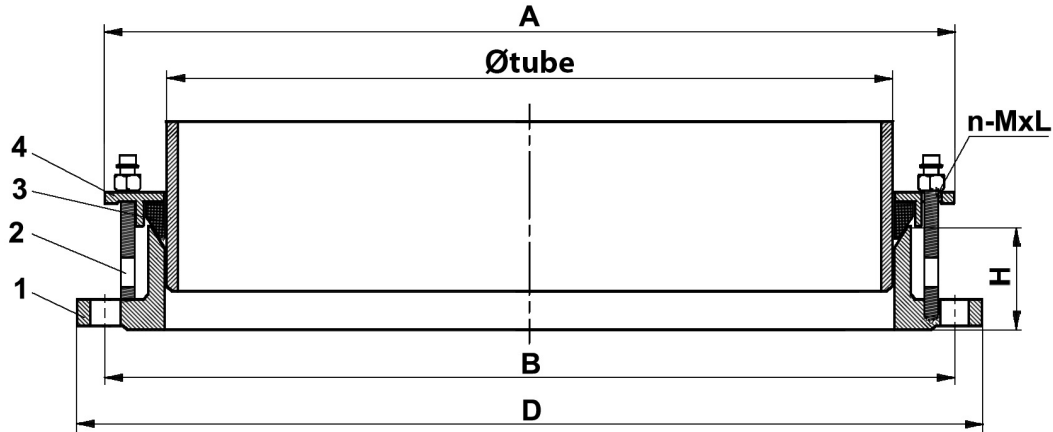

Rep.	Désignation	Matière	Standard
1	Body	Ductile iron GGG50	EN 1563
2	Screw*	Stainless steel AISI 304	1449-2 304 S15
3	Gasket	ACS EPDM	EN 681-1
4	Counter flange	Ductile iron GGG50	EN 1563

* In option Inox AISI 316

Epoxy coated body according to EN 14901
RAL 5015, 250 µm tickness

DIMENSIONS

DN		Ø tube	A	B		D	H	n-MxL	Weight (kg)
mm	inch			PN10	PN16				
DN700	28"	700-716	874	840	840	902	115	12-M16x180	89.5
DN800	32"	802-816	950	950	950	1023	116	12-M16x180	140
DN1000	40"	1000-1016	1170	1160	1170	1248	118	14-M16x190	180

WORKING CONDITIONS

Maximum working pressure: 16 bar
Maximum working temperature : 90°C

Tecofi France

83 rue Marcel Mérieux - 69960 Corbas
Tél. +33 (0)4 72 79 05 79 - Fax. +33 (0)4 78 90 19 19
E-mail : sales@tecofi.fr - www.tecofi.fr

